



MCLVB01 & MCLVB02 - ON/OFF MAGNETIC VALVE BOX LIFTER

OPERATION MANUAL

INTRODUCTION

READ AND UNDERSTAND THIS MANUAL BEFORE USING YOUR MAGNETIC VALVE BOX LIFTER

This Valve Box Lifter is designed to lift steel and cast iron castings from the ground. Meter Pit Covers, Valve Box Covers, Small Panels and lids and most castings up to 75 Lbs. This device has tremendous holding power as well as a great amount of shear force holding strength to prevent sideways movement. This product also works well to lift steel plate, parts, pipe, bar and rod stock up to 75 Lbs.

GENERAL INFORMATION

- » All Magnets need to be kept at a safe distance from all magnetic storage devices, electronics, credit cards etc...
- » Ensure that the Magnet is stored in the "OFF" position when not in contact with ferrous metals. The Valve Box Lifter can be left "ON" or "OFF" indefinitely without harm. When "ON" and near ferrous metals, there will be a sudden and powerful attraction.
- » Never use a Magnetic Valve Box Lifter to lift heavy materials (MCLVB01 over 50 lbs., 23 kg. MCLVB02 over 75 lbs., 34 kg.), although it is ideal for light weight metal, debris cleanup, nuts and bolts, metal shavings, etc...
- » DO NOT attempt to disassemble the Magnetic Valve Box Lifter; there are no user serviceable parts inside the device.
- » All Magnetic Valve Box Lifter products are designed for normal work/jobsite conditions, do not use underwater or in a hazardous environment.
- » DO NOT use the Magnetic Valve Box Lifter if it is damaged or is not working properly. Severe injury can occur if this device is not used properly and safely.
- » DO NOT expose the Magnet to temperatures above 180 degrees Fahrenheit (82° Celsius). High temperatures will permanently degrade the Magnet's effectiveness and may result in an unsafe condition.
- » Never use a Valve Box Lifter for OVERHEAD LIFTING or to transport materials higher than necessary.
- » Not recommended for painted or finish coated surfaces as these will reduce the magnetic bond and the finish may be damaged.
- » This product contains PTFE lubricant. For SDS information contact Industrial Magnetics, Inc.
- » Always keep the bottom of the magnet clean and free of debris and rust. If needed wipe with WD40 or light oil.

TO USE THE VALVE BOX LIFTER

- » Always **test the connection** before attempting to use the Magnetic Valve Box Lifter to ensure that it is capable of holding the material securely.
- » **Always ensure that the item to be lifted is free to be lifted!** Stuck covers must be banged or pried loose before lifting with the Valve Box Lifter.
- » **Numerous factors can negatively affect the strength** of the magnetic bond. Dirt, debris, oils and grease, painted surfaces and any gap between the Magnet and the metal surface (cast textures, words, logos, etc.) will decrease the bond. **Ensure that the metal is clean** and free of these factors.
- » **Thicker metals will be held more strongly than thinner metals.** E.g.: 1/4" steel will be held more strongly than thin gauge metals.
- » **User must test every bond to determine the suitability of the magnet to hold the material.** Lift 1-3" and shake gently to verify hold.
- » **Lift the material straight up.** Attempting to pry the cover loose or lift at an angle may cause the magnet to lose its hold.
- » **Ensure that the magnet is centered on the material being lifted.** Material may slide off the magnet if it is not held in a horizontal position.
- » **Ensure that when stacked steel are present, that only one piece is being lifted at a time.**
- » **Valve Box Lifters are rated to carry up to 75 lbs. (34 kg.) of material under ideal conditions.**
- » **Avoid sudden jerking or Shock force** as this will cause the Magnet to lose its hold.
- » Operator shall immediately stop using the lifting magnet if any improper performance or conditions exist during the lift.
- » This magnetic lifter is designed for straight, flat horizontal lifting, never allow a lifted object to alter its plane from horizontal.
- » Never stand under load being lifted or place any part of your body under the load.
- » DO NOT lift a load higher than necessary.
- » Only use magnetic lifts on material that does not flex or bend.
- » Always ensure that the full face of the magnet is in contact with the load.
- » Always ensure that the lifted materials will not come into contact with any obstruction or body part while being carried.
- » This Magnetic Valve Box Lifter is not designed to be used as a welding ground clamp or as part of an electrical circuit.
- » For safe operation, the bottom surface of the Magnet must always be Flat and Smooth. If necessary, it is possible to sand the Magnet face smooth using 400 grit sandpaper and a flat surface. Always file any burrs that would interfere with full contact.



MAGNETIC VALVE BOX LIFTER OPERATION

- » The handle on this Valve Box Lifter must be turned clockwise 180 degrees until it stops in order to be turned "ON". It is not possible to hold the magnet in place unless fully turned "ON".
- » For ease of use always place foot next to Foot Stop to hold Valve Box Lifter in place when turning "ON".
- » **DO NOT turn "ON" unless in contact with ferrous metal.**
- » To release the Valve Box Lifter push down and turn the handle in the counter clockwise direction until it stops. The Valve Box Lifter will turn "OFF" and release immediately upon turning the handle, Use caution to ensure that it is safe to release the Valve Box Lifter and that nothing will fall or become dangerous.
- » This Valve Box Lifter is capable of exceptional Break-Away force holding power; Valve Box Lifters are exceptionally strong in Shear Force as well, Prying force is the least powerful of the holding capabilities and great care must be used when attempting to use this device with Pry force. See illustrations below.

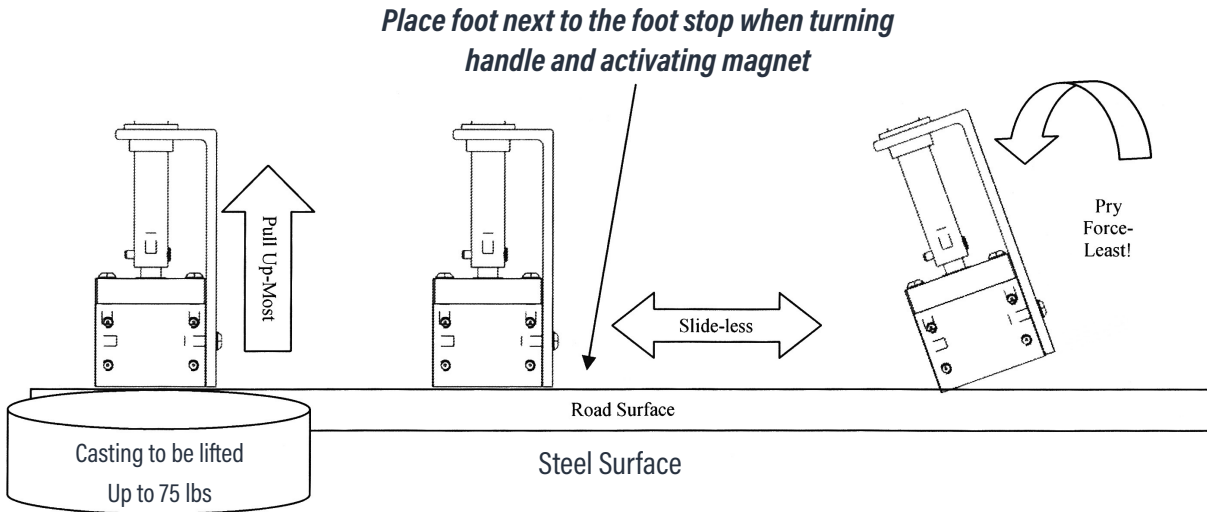

DE-RATING THE RATED LOAD CAPACITY

Numerous factors can reduce the Safe Working Load of a Lifting Magnet. Additional factors include the type of metals being lifted. **Your results will be different** depending on such conditions as;

- » Surface Condition
- » Surface Flatness
- » Surface Smoothness
- » Cast textures, words, logos, etc.
- » And Other Conditions

AFTER THE LIFT

- » Always check the Valve Box Lifter to ensure that no damage occurred and that it still complies with all requirements listed above.
- » Always wipe off any debris or contaminants that became attracted to the magnet that would prevent a safe lift in the future.
- » Always store the magnet in a safe location and in the "OFF" position to ensure that no damage can occur or accidental contact with metal can be made. Ensure that the storage area is free of humidity, debris, shavings etc.
- » Wipe a light coating of oil on the magnet as needed to prevent rust.
- » For safe operation, the bottom surface of the magnet must always be flat and smooth. If necessary, it is possible to sand the magnet face smooth using 400 grit sandpaper and a flat surface. Always file any burrs that would interfere with full contact.

LIMITED WARRANTY

These products are covered by a One Year Limited Warranty on Material and Workmanship. Warranty is Non-Transferable. We reserve the right to inspect all product claims under warranty. Any alteration of the device voids this warranty. User assumes all risk for the proper use of this device and for ensuring product suitability for intended application. This warranty shall not cover any incidental or consequential damages due to the improper use or failure of this device.